



INSTRUCTION MANUAL



1WMPD4003659

1. Safety Precautions

All safety messages are identified by the following, "WARNING" or "CAUTION", of ANSI Z535.4 (American National Standard Institute: Product Safety Signs and Labels). The meanings are as follows:

	WARNING A potentially hazardous situation which, if not avoided, could result in death or serious injury.
	CAUTION A potentially hazardous situation which, if not avoided, may result in minor or moderate injury.

- ❑ This manual is subject to change without notice at any time to improve the product.
- ❑ Product specifications are subject to change without any obligation on the part of the manufacturer.
- ❑ When using the AD-1612, the following safety precautions should always be observed.

CAUTION

- ❑ Do not disassemble the AD-1612. Disassembling may cause damage to the AD-1612. Damage caused by disassembling will not be covered by the warranty. Contact your local A&D dealer if the AD-1612 needs service or repair.
- ❑ If a problem has occurred and you cannot resolve it, stop using the AD-1612.

2. Introduction

This manual describes how the AD-1612 comparator buzzer works and how to get the most out of it in terms of performance. Read this manual completely before using the AD-1612.

3. About the AD-1612

3-1. Features

- ❑ By connecting the balance / scale comparator output to the AD-1612, up to five levels of comparator lights and up to five types of buzzer sounds can be output.
- ❑ The AD-1612 can light up or sound according to the contact input. (short-circuited between each pin and COM)
- ❑ The buzzer sound level can be adjusted using the volume knob on the front panel of the device.
- ❑ Power for the AD-1612 is provided using the AC adapter provided for the balance / scale. By connecting the scale and AD-1612 using the provided DC cable, power can be provided to both the balance / scale and AD-1612 by using a single AC adapter.
- ❑ By connecting the signal lines to the terminals on the rear side of the device, the RS-232C can be bypassed to the D-sub 9 pin connector.

3-2. Precautions for use

- ❑ Carefully confirm the AC adapter rating before connecting it to the device.
Failure to do so may result in mechanical damages to the internal circuit or result in buzzer sound or LED output fluctuating.
- ❑ Adjusting the volume for buzzer sound level to MIN. means the buzzer will sound very quietly, not that it will output no sound at all. To set the buzzer to output no sound, the device must be set using the function settings. Refer to "9. Function Settings".
- ❑ The COM is internally connected to GND. Refer to "8. Internal Configuration".
Connecting the plus polarity of the external device to the COM or adding high voltage to the HI / LO terminals side may cause mechanical damage.
- ❑ If the desktop stand slips, attach the provided rubber feet to the bottom of the stand.

4. Parts Description / Accessories

4-1. AD-1612

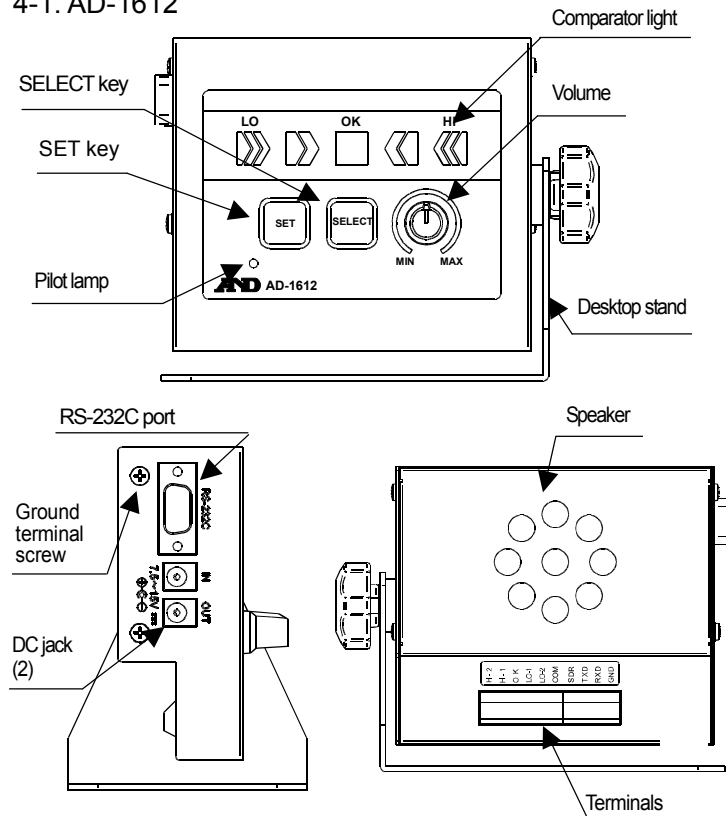

4-2. Accessories

- (1) DC cable (1.8m): 1 pc
- (2) Rubber feet : 4 pcs
- (3) Instruction manual (This document)

5. Mode

	Mode	Operations	Entering the mode	Pilot lamp
(1)	Normal mode	Performs comparator operations	At start up Press and hold the [SET] key in setting mode	On
(2)	Setting mode	Sets LED brightness and buzzer sound	Press and hold the [SET] key in normal mode	Off

6. How to Connect

6-1. Connecting the comparator contact

Connect the signal lines of the relay contact output of the device to the 1st to 6th pin of the terminal block.

Note Confirm "8. Internal Configuration" beforehand to properly perform the wiring.

Pin No.	Signal name	Comparator light
1	HI-2	Red: Right end
2	HI-1	Yellow: Second from the right
3	OK	Green: Center
4	LO-1	Yellow: Second from the left
5	LO-2	Red: Left end
6	COM	----

6-2. Connecting the RS-232C

Terminal block: Connect the signal lines of the balance / scale to the 7th to 10th pin of the terminal block.

D-sub 9 pin: Connect the cable to the connector on side of the device.

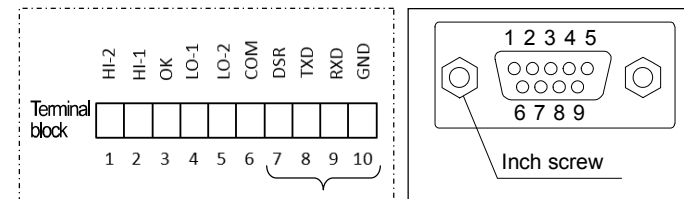

Scale connection example (FG communication option)

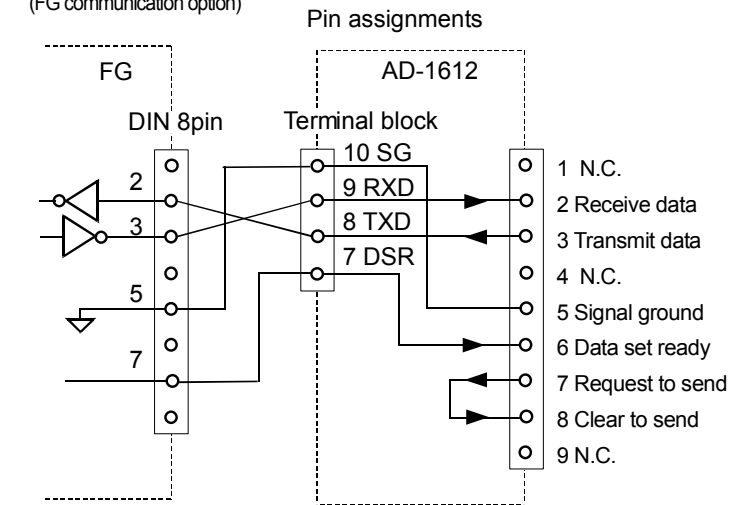

6-3. Power Supply

- ❑ Power is supplied to the AD-1612 by the AC adapter when connected to the [IN] DC jack. (The pilot lamp is on.)
- ❑ Confirm the specifications of the AC adapter before inserting it. (DC 7.5 to 15 V)
- ❑ When using the AC adapter provided for the balance / scale, connect the AC adapter to the [IN] DC jack. Then, connect the DC cable to the [OUT] DC jack and balance / scale.

Note 1 When the buzzer is at the maximum volume, the AD-1612 needs up to 500 mA of current. When using at a large buzzer volume, supply power to the balance / scale and AD-1612 with a separate AC adapter. (Refer to "11-2. Options".)

Note 2 When grounding the device, use the screw (including inner clip washer) on the side of the device as the grounding terminal.

6-4. Example

< Connecting the comparator output of the EK-i series >

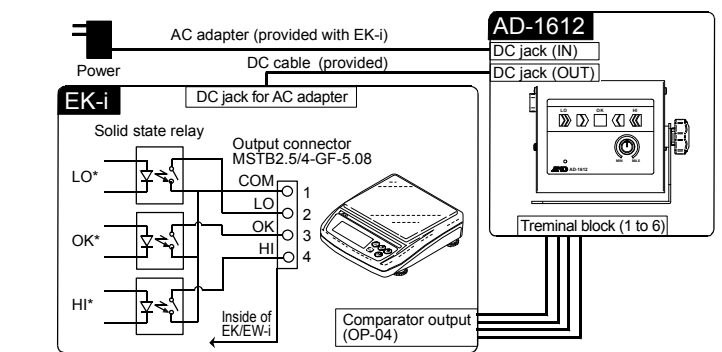

** Comparator output terminal assignment table **

EK-i		AD-1612			
Terminal	Terminal	Terminal	Terminal	Color	LED Position
Pin No.	Description	Pin No.	Description		
4	HI	2	HI-1	Yellow	Second from the right
3	OK	3	OK	Green	Center
2	LO	4	LO-1	Yellow	Second from the left
1	COM	6	COM		----

Refer to the A&D website for other information on connections.

< Bypassing the RS-232C output of the FG series >

- When the RS-232C is bypassed, power for the AD-1612 itself is not needed..

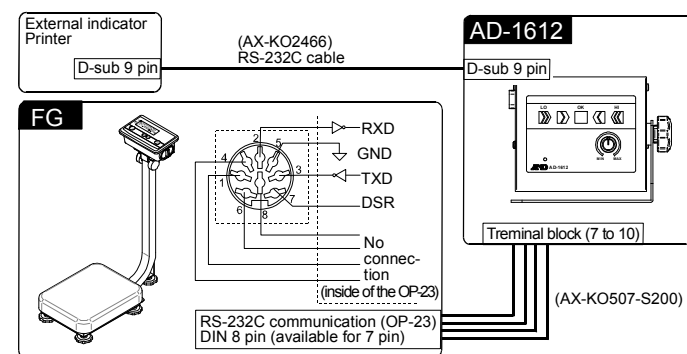

** RS-232C communication terminal assignment table **

FG (AX-KO507)			AD-1612			
DIN 8 connector		Discrete wire	Terminals		D-sub 9 connector	
Pin No.	Description	Cable color	Pin No.	Description	Pin No.	Description
7	DSR	Blue	7	DSR	6	DSR
2	RXD	White	8	TXD (receive data)	3	TXD
3	TXD	Red	9	RXD (transmit data)	2	RXD
5	SG	Yellow	10	SG	5	SG

7. How to Use

- 1) Wire to the terminal block.
→ Refer to "6. How to Connect".
- 2) Connect the device to the power using the AC adapter.
→ Pilot lamp is on.
- 3) Set the comparator brightness and buzzer.
(only at initial use and setting change)
→ Refer to "9. Function Settings".
- 4) Turn on the power for external devices connected to the AD-1612.
- 5) Each comparator light lights up and the buzzer sounds according to the contact outputs.

Priority of buzzer sound when at least 2 LEDs simultaneously light up
HI 2 > LO 2 > HI 1 > LO 1 > OK

8. Internal Configuration

Five sets of the following configurations are included in the device.

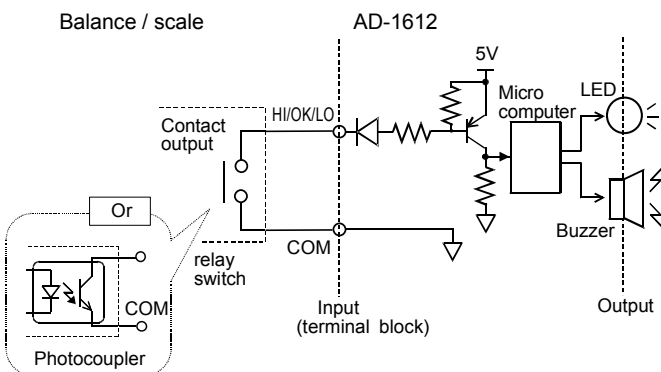

Comparator input	Contact input (Relay/Switch/Photocoupler)
COM	Common terminal (6th pin of terminal block)
ON	1V or less (1mA at short circuit)
OFF	2.5V or more

9. Function Settings

9-1. How to set

1. In normal mode, press and hold the [SET] key.
Pilot lamp: on (normal mode)
→ off (setting mode)
2. All LEDs are on.
3. Press the [SELECT] key several times to select the LED brightness. (Refer to "9-2 Function List".)
4. Press the [SET] key to confirm.
Confirm brightness → Go to next item settings
5. The HI-2 LED is on and the buzzer sounds with the HI-2 setting sound. (Factory settings are set to no sound.)
6. Press the [SELECT] key several times to select the buzzer sound. (Refer to "9-2 Function List".)
7. Press the [SET] key to confirm.
Confirm HI-2 sound → Go to next item settings
8. The HI-1 LED is on and the buzzer sounds with the HI-1 setting sound.
9. Repeat Steps 6 and 7 four times until LO-2 is set.
10. Return to Step 2 after finishing the LO-2 setting.
11. Press and hold the [SET] key after the settings for all items are finished to return to normal mode.
Pilot lamp: off (setting mode)
→ on (normal mode)

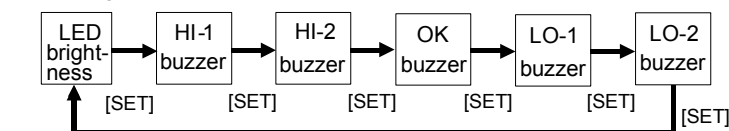

- Note 1 By pressing and holding the [SET] key even before settings are completed for all items, the device returns to normal mode after memorizing the settings for items that have been configured.
- Note 2 Settings are maintained in non-volatile memory even when the power is turned off.
- Note 3 In setting mode, the device does not perform comparator operations. Return the device to normal mode to use comparator mode after setting is complete.

9-2. Function list

Step	Items	Parameters	Descriptions
3	Comparator light brightness	0	Off
		1	Dark
		2	↕
		3	
		4	Bright
5			
6	Buzzer sound for the comparator output	0	No sound
		1	Repeating short beep
		2	Two repeating short beeps
		3	Three repeating short beeps
		4	Rapid short beeps
5	Long beep		

10. Trouble Shooting

Error	Possible causes	Remedies
1 The pilot lamp does not light up even when the device is connected to the power using the AC adapter.	When the power cannot be provided	
	The proper AC adapter is not used.	Use a proper AC adapter after confirming output rating of the AC adapter. Refer to the A&D website for a proper AC adapter made by A&D.
	Poor AC adapter connection	Fully insert the AC adapter.
	When the device is not in normal mode	
	The device is in setting mode.	Press and hold the [SET] key to return to normal mode.
2 The comparator light cannot properly be functioned.	Poor connection	Firmly reconnect the signal wires to the terminals after confirming the terminals.
	The device is not receiving a signal.	Confirm the comparator output of the balance or scale.
	The connection port is not correct.	Confirm the connection of the port.
3 Buzzer sound fluctuates.	The proper AC adapter is not used.	Use a proper AC adapter after confirming output rating of the AC adapter.
	The front of the speaker is blocked.	Keep the device clean after confirming there is nothing covering the holes on the rear side of the device.
4 Bypass for the RS-232C cannot properly be functioned.	Connection error	
		Confirm the RS-232C connector again. → Refer to "6. How to Connect". Firmly reconnect the signal wires to the terminals after confirming the terminals.

Note If the remedies above do not resolve the problem or if other problems occur, contact your local A&D dealer.

11. Specifications

11-1. General

Model name	AD-1612
Power supply	AC adapter (DC7.5V to 15V / 500mA)
Operating temperature range	-10°C to 40°C (no condensation)
Display	LED: HI-2 (red)/HI-1 (yellow)/OK (green)/LO-1 (yellow)/LO-2 (red)
Buzzer sound level	Up to approx. 95 [dB]
Power consumption	Approx. 2.1 VA (when LEDs are lit and buzzer sound is at maximum)
Dimensions (W×D×H)	147 x 80 x 115 [mm]
Mass (including the stand)	Approx. 700 [g]
Accessories	DC cable, rubber feet and instruction manual
Connectible devices	Balances or scales made by A&D that are equipped with a comparator option (Refer to the A&D website for details)
Connector shape	RS-232C : D-sub 9 pin, male

A&D HP
<http://www.aandd.jp/products/weighing/wproduct.html#peripherals>

11-2. Options sold separately

- Pole mounting bracket
AD1612-14
- Communication cable
AX-KO507-S200 DIN 7 – discrete wire, 2m
AX-KO5862-S200 DIN 8 – discrete wire, 2m
AX-KO5862-N200 Discrete wire - Discrete wire, 2m
- AC adapter:
AX-TB280 C/BF plug, 9V, 500mA
AX-TB275 A plug, 9V, 500mA
- Note When supplying power to balance / scale, use the AC adapters supplied with them.

A&D Company, Limited

3-23-14 Higashi-Ikebukuro, Toshima-ku, Tokyo 170-0013, JAPAN
Telephone: [81] (3) 5391-6132 Fax: [81] (3) 5391-6148 <http://www.aandd.jp/>

A&D ENGINEERING, INC.

1756 Automation Parkway, San Jose, California 95131, U.S.A.
Telephone: [1] (408) 263-5333 Fax: [1] (408) 263-0119 <http://www.andonline.com/>

A&D INSTRUMENTS LIMITED

Unit 24/26 Blacklands Way, Abingdon Business Park, Abingdon, Oxfordshire OX14 1DY, United Kingdom
Telephone: [44] (1235) 550420 Fax: [44] (1235) 550485 <http://www.aandd-eu.net/>

A&D AUSTRALASIA PTY LTD

32 Dew Street, Thebarton, South Australia 5031, Australia
Telephone: [61] (8) 8301-8100 Fax: [61] (8) 8352-7409 <http://www.aanddaustralia.com.au/>

A&D KOREA Limited

Manhattan Building 8th Floor, 36-2 Yoido-dong, Youngdeungpo-gu, Seoul, 150-749 Korea
Telephone: [82] (2) 780-4101 Fax: [82] (2) 782-4280 <http://www.andk.co.kr/>

OOO A&D RUS

Business-Center "Vereyskaya Plaza-2" 121357, Russian Federation, Moscow, Vereyskaya Street 17
Telephone: [7] (495) 937-33-44 Fax: [7] (495) 937-55-66 <http://www.aandd.ru/>

A&D INSTRUMENTS INDIA PRIVATE LIMITED

509, Udyog Vihar, Phase-V, Gurgaon - 122016, Haryana, India
Telephone: [91] (124) 4715555 Fax: [91] (124) 4715599 <http://www.aanddindia.in/>